

HiLight H6+

Your site, your light!

The **HiLight H6+** light tower offers **low operational costs, reduced noise levels** and **increased illumination coverage**. It is ideal to use in tough environments, such as applications in construction, mining, and rental companies. The next generation of LED floodlights are more efficient and provide optimal light distribution covering an area up to 6,000m².

The **HiLight H6+** comes with three different ways of transporting



Straight / Foldable / Adjustable tow bar



Forklift slots



Integrated lifting point

Our renowned **HardHat®** body protects the inside of the unit from the elements ensuring lasting performance. This 'toughness' makes it the ideal solution for environments within construction and mining. And being the quietest diesel drive light tower in the market (just 55dBA at 7m), it's also perfect for events and urban environments.

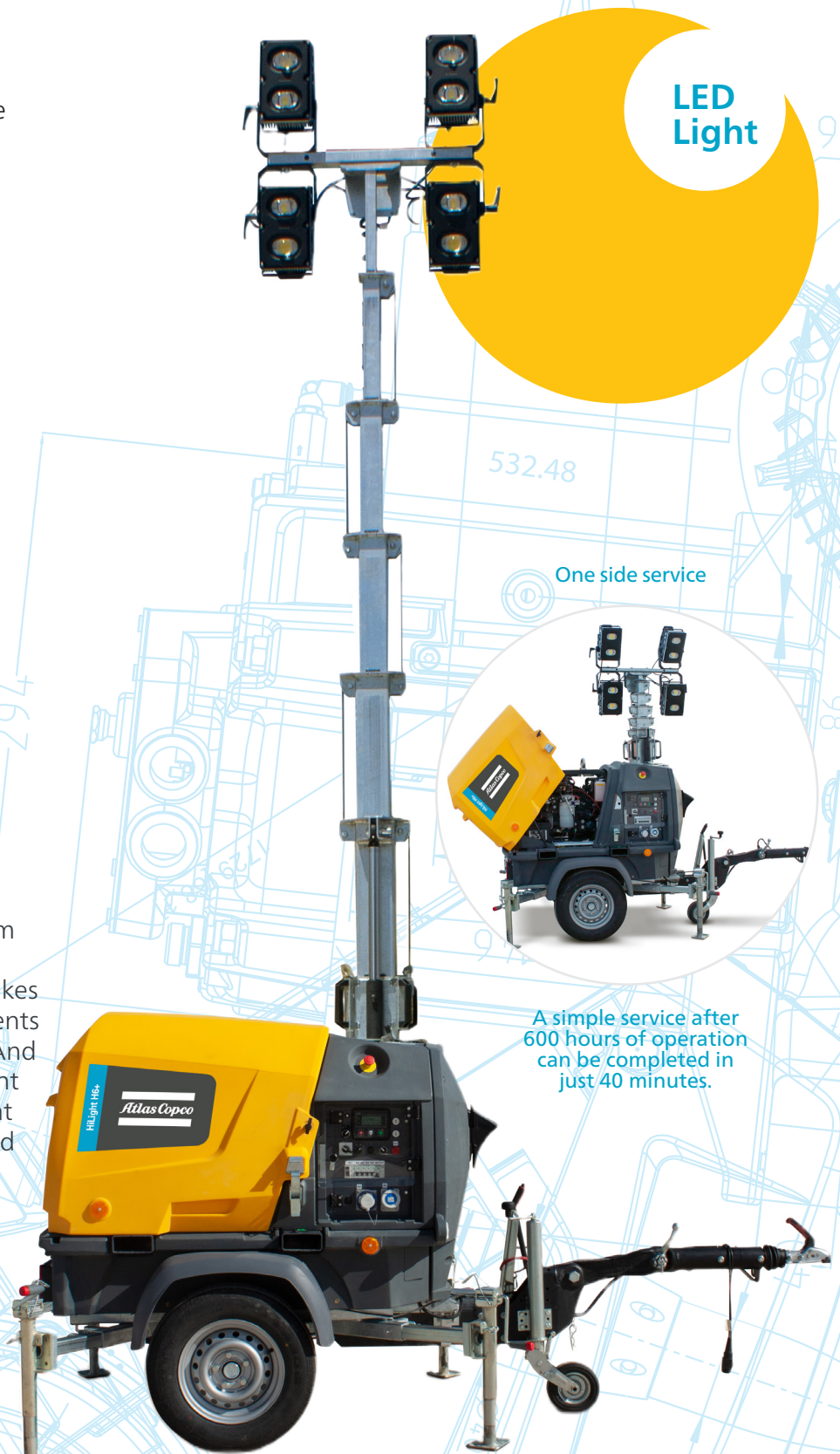

LED Light

One side service



A simple service after 600 hours of operation can be completed in just 40 minutes.

HardHat®
BODY



UP TO
40% LESS
FUEL AND
CO₂ EMISSIONS*



40 Min
EVERY 600 Hrs



**LIGHT
COVERAGE**
6.000m²



LIFE SPAN
50.000
Hrs







-5dB(A)
**LOWER
NOISE**



Performance Data		HiLight H6+
Rated Frequency	Hz	50
Rated Voltage	VAC	230
Rated Power (PRP)	kW	2.7
Operating Temperature (min/max)	•C	-20 40
Sound Power Level (LwA)	dB(A)	82
Sound Pressure Level (LpA) at 7m	dB(A)	55



HiLight H6+

Light coverage m ² (average 20 luxes)		6000 (average 20 luxes)
Lamps		LED
Mast		Vertical hydraulic
Extra features		HardHat® Canopy

LISTER WILDER
Machinery Specialists

Richard North

Phone: 07342 034 801

Email: richard.north@listerwilder.co.uk

www.listerwilder.co.uk

Authorised Distributor
Of

Atlas Copco